

ADV-116-1 立卧两用型砂带机

Vertical/horizontal multi-use sand belt grinder



Advanced deburring, grinding and polishing solutions

ADD: Hema Road, Longtang Industrial Park, HeFei China, 230000

TEL/whatsapp: +86 156556556997/+86 17775302563

FAX: +86 551 67365271

EMAIL: melody@advanpolish.com/sales3@advanpolish.com

WEB: www.advgrinding.com/www.advgrinding.en.alibaba.com

一、机器参数 Machine Parameter

电压 Voltage	220V/ 50HZ single phase (customized 380V)	
电机 (保修 12 个月) Motor(guarantee for 12 months)	材质 material	铜线铝壳 copper wire, aluminium shell
	功率 power rate	1.5KW
	转速 rotation	2800r/min
变频器 (保修 18 个月) Frequency changer(guarantee for 18 months)	矢量变频 vector frequency	
	功率 power rate	2.2KW
砂带 sand belt	尺寸 size	1800*50mm (length*width) 使用弧磨架组砂带最短支持 1600*50 (长*宽) Minimum size for Arc grinding frame: L1600*W50 使用平磨架时最长支持 2100*50 (长*宽) Maximum size for flat grinding frame: L2100*W50
	速度 speed	0-30 米/秒, 通过变频器可无极变速 0-30m/s, speed variable by changing frequency changer
机器底座尺寸 machine base size	300*350mm (length*width)	
机器尺寸 machine size	700*580*380mm (L*W*H, 使用平面轮时) When using flat grinding wheel	
机器重量 (含全部配件) machine weight(including all tools)	89KG	
木箱尺寸 (夹板) Wooden case size(plywood)	640*460*450mm (L*W*H)	
机器加木箱重量 total G.W	98KG	



Advanced deburring, grinding and polishing solutions

ADD: Hema Road, Longtang Industrial Park, HeFei China, 230000

TEL/whatsapp: +86 156556556997/+86 17775302563

FAX: +86 551 67365271

EMAIL: melody@advanpolish.com/sales3@advanpolish.com

WEB:www.advgrinding.com/www.advgrinding.en.alibaba.com

二、机器配件及使用方法 Machine tools and usages

1、平磨架 Flat grinding frame

铝轮尺寸：60*60mm（直径*厚度），轴承号码 6004Z，2 个。

Aluminium wheel size: dia60mm*thick60mm, bearing model number: 6004Z*2sets

使用方法：安装在机器背后的孔槽中，并锁紧固定。

Application: install in the slot of machine back, and lock it.

用途：用于垂直研磨。

Usage: For vertical grinding

machine size=700*380*580 mm

①

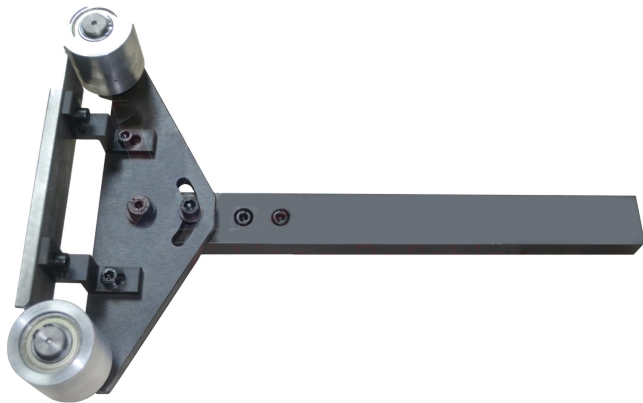

Advanced deburring, grinding and polishing solutions

ADD: Hema Road, Longtang Industrial Park, HeFei China, 230000

TEL/whatsapp: +86 156556556997/+86 17775302563

FAX: +86 551 67365271

EMAIL: melody@advanpolish.com/sales3@advanpolish.com

WEB: www.advgrinding.com/www.advgrinding.en.alibaba.com

2、弧磨架 Arc grinding frame

小弧磨轮尺寸:

Small arc grinding wheel size:

小弧磨轮—30*66.57mm (直径*厚度), 轴承号码 F608Z。

Dia30mm*thick66.57mm, bearing model number: F608Z

小弧磨轮—20*77.64mm (直径*厚度), 轴承号码 F608Z。

Dia20mm*thick77.64mm, bearing model number: F608Z

使用方法: 安装在机器背后的孔槽中, 并锁紧固定。

Application: install in the slot of machine back, and lock it.

用途: 用于较小的弧位研磨。

Usage: For small arc part grinding

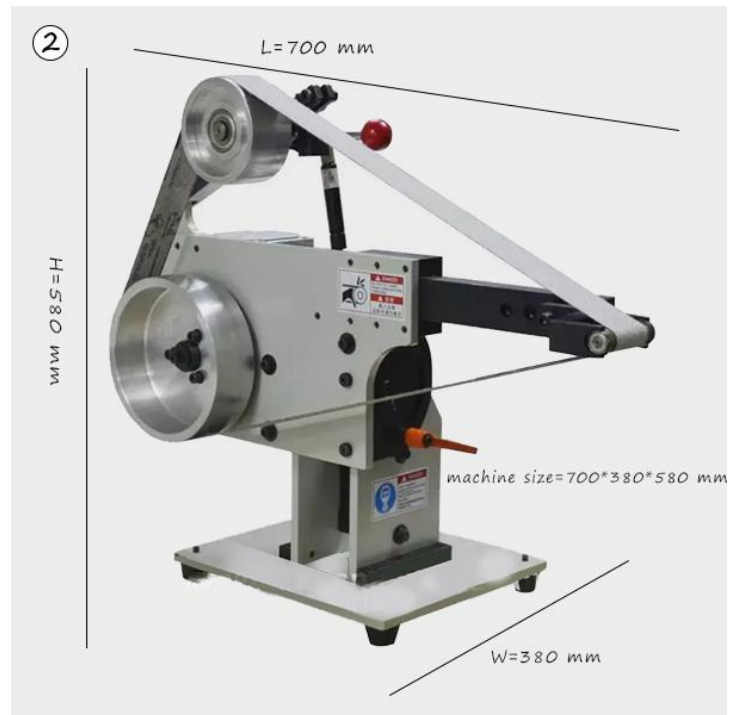

Advanced deburring, grinding and polishing solutions

ADD: Hema Road, Longtang Industrial Park, HeFei China, 230000

TEL/whatsapp: +86 156556556997/+86 17775302563

FAX: +86 551 67365271

EMAIL: melody@advanpolish.com/sales3@advanpolish.com

WEB: www.advgrinding.com/www.advgrinding.en.alibaba.com

3、胶轮磨架 rubber wheel frame

胶轮尺寸：200*50mm（直径*厚度），轴承号码 6204Z

Rubber wheel size: dia200*thick50mm, bearing model number: 6204Z

使用方法：安装在机器背后的孔槽中，并锁紧固定。

Application: install in the slot of machine back, and lock it.

用途：用于较大的弧位研磨。

Usage: For bigger arc part grinding

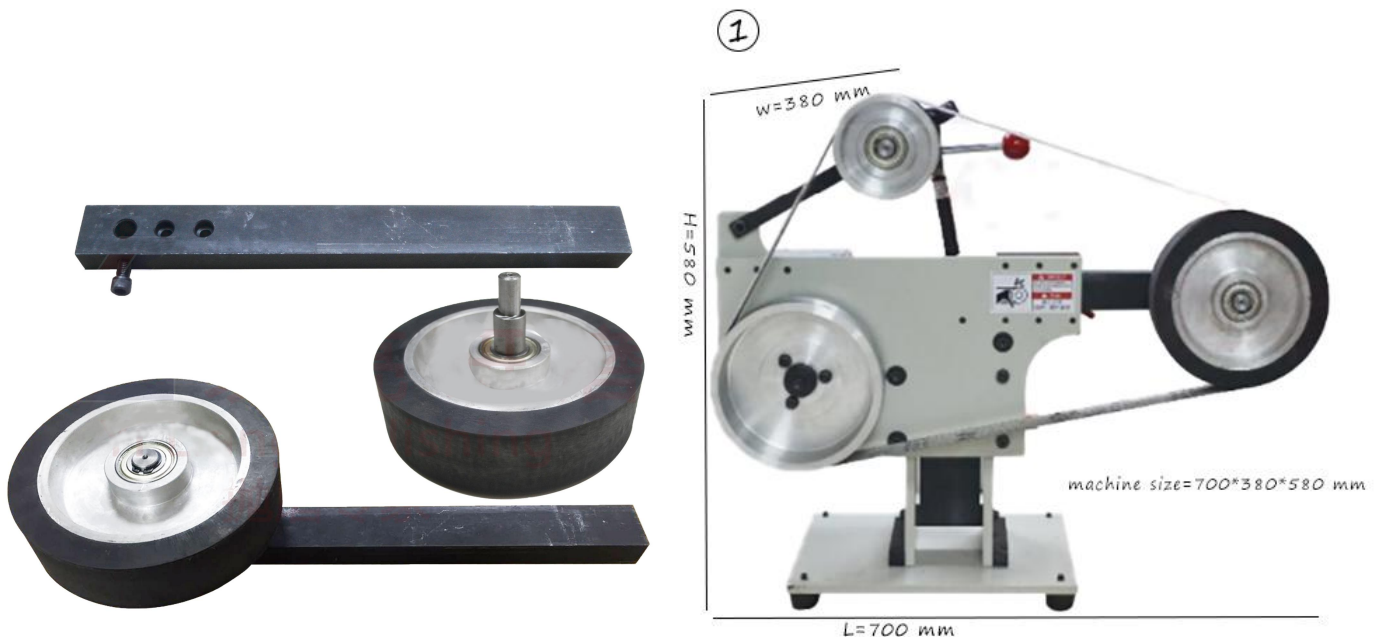

4、可拆卸孔槽 Detachable slot hole

此孔槽可以自主拆卸，自由与以上三种磨架组合，用于固定工作平台。

This slot hole is detachable, for fixing working table. Above all 3 kinds of grinding frames are matched.

5、万向工作平台 Multi-directional working table

工作台可万向调节，不同角度和方向可自由调节，前后、左右、工作台面也可以调整角度。工作平台和上述三种组合可以形成 4 种使用方式。

Direction of table is multi-adjustable in different angles and direction including in and out, left and right, and work table. Working table and above 3 kinds of combination have 4 kinds of using methods.



Advanced deburring, grinding and polishing solutions

ADD: Hema Road, Longtang Industrial Park, HeFei China, 230000

TEL/whatsapp: +86 156556556997/+86 17775302563

FAX: +86 551 67365271

EMAIL: melody@advanpolish.com/sales3@advanpolish.com

WEB: www.advgrinding.com/www.advgrinding.en.alibaba.com

Multi-directional working table
万向工作平台

Detachable slot
可拆卸孔槽

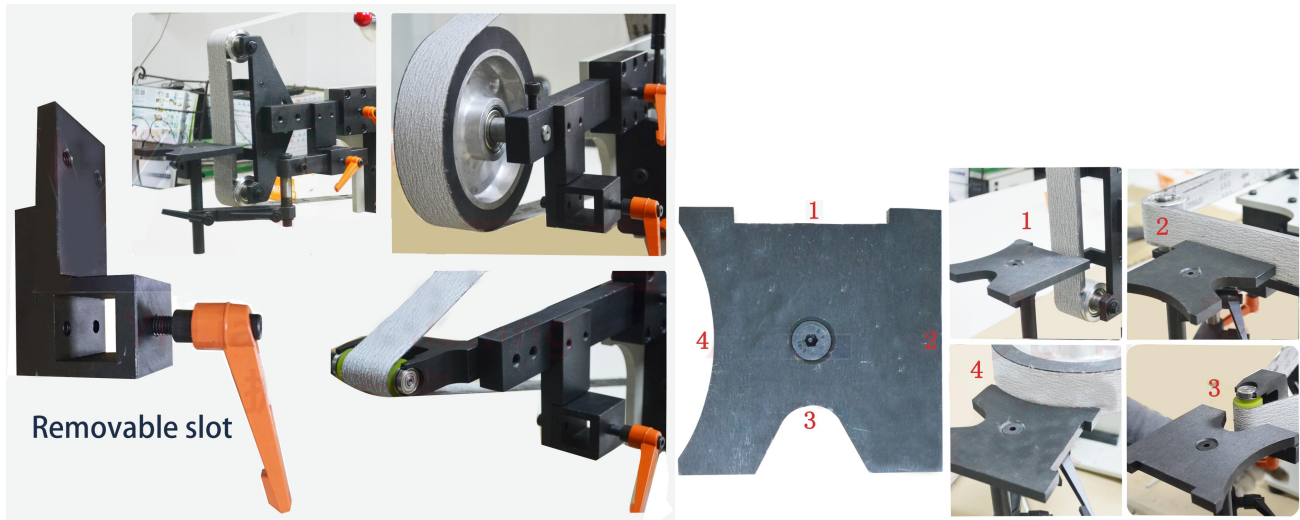

6. 额外加一个工作平台(Add an extra working platform)

尺寸: 130x260mm. Size: 130*260mm



7. 砂带保护挡板 Abrasive belt protection board

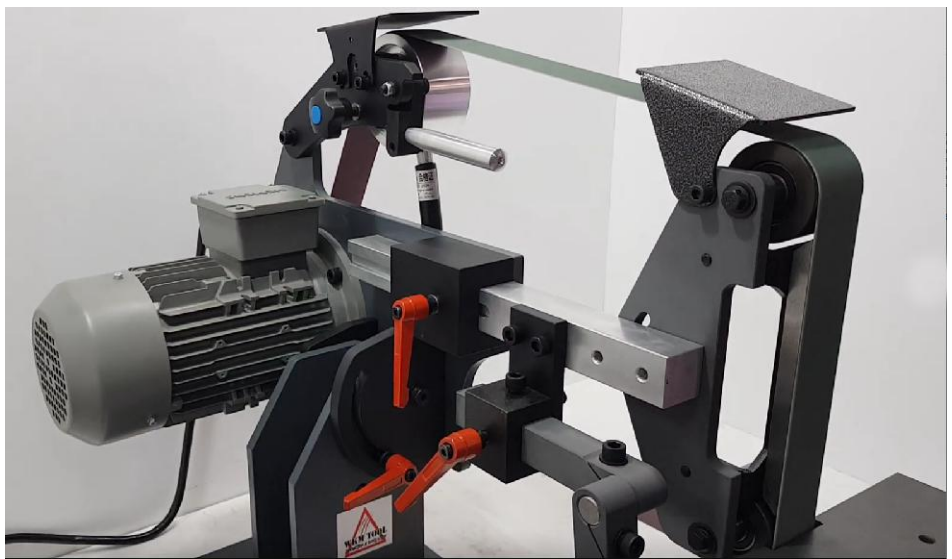
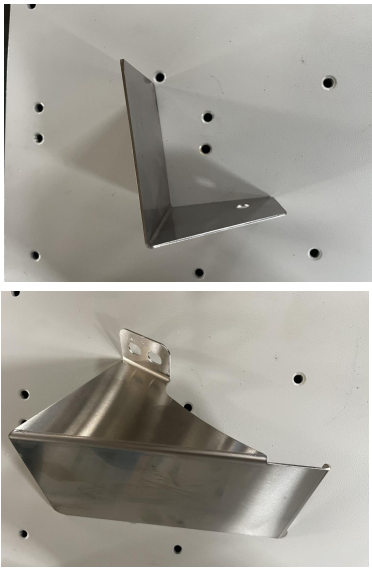

8. 机器包含所有项目 Machine contains all items



Pure copper wire motor



Nikko 1.5kw vector inverter



Multi-station workbench
Custom workbench

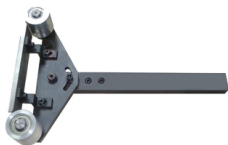

Flat grinding frame



Arc grinding frame

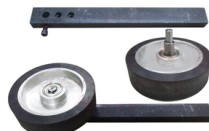

Rubber wheel frame



Advanced deburring, grinding and polishing solutions

ADD: Hema Road, Longtang Industrial Park, HeFei China, 230000

TEL/whatsapp: +86 156556556997/+86 17775302563

FAX: +86 551 67365271

EMAIL: melody@advanpolish.com/sales3@advanpolish.com

WEB: www.advgrinding.com/www.advgrinding.en.alibaba.com

9、随机附赠砂带一条 1 piece of sand belt for free random

砂带尺寸: 1800*50mm (长*宽)

Belt size: L1800mm*W50mm

使用方法: 安装砂带—把砂带套在机器大铝轮和磨架轮子上, 在套上机器上小铝轮前留出约一寸的距离, 往下按压红色把手, 把砂带套在机器的小铝轮上, 松开红色把手, 并让它自然恢复原位, 砂带就可以套紧了。套好砂带后扭动蓝色开关调整砂带位置。拆卸砂带—只需要往下按压红色把手, 取出砂带即可。

Application:1. Put sand belt on the big aluminium wheel and grinding frame.

2. Put the belt aside the small aluminium wheel, and press down the small aluminium wheel with the red handle, then put the belt around the wheel and release the handle.

3. Adjust sand belt by twisting blue button after fixing sand belt.

4. Press down the red handle to disassemble sand belt.

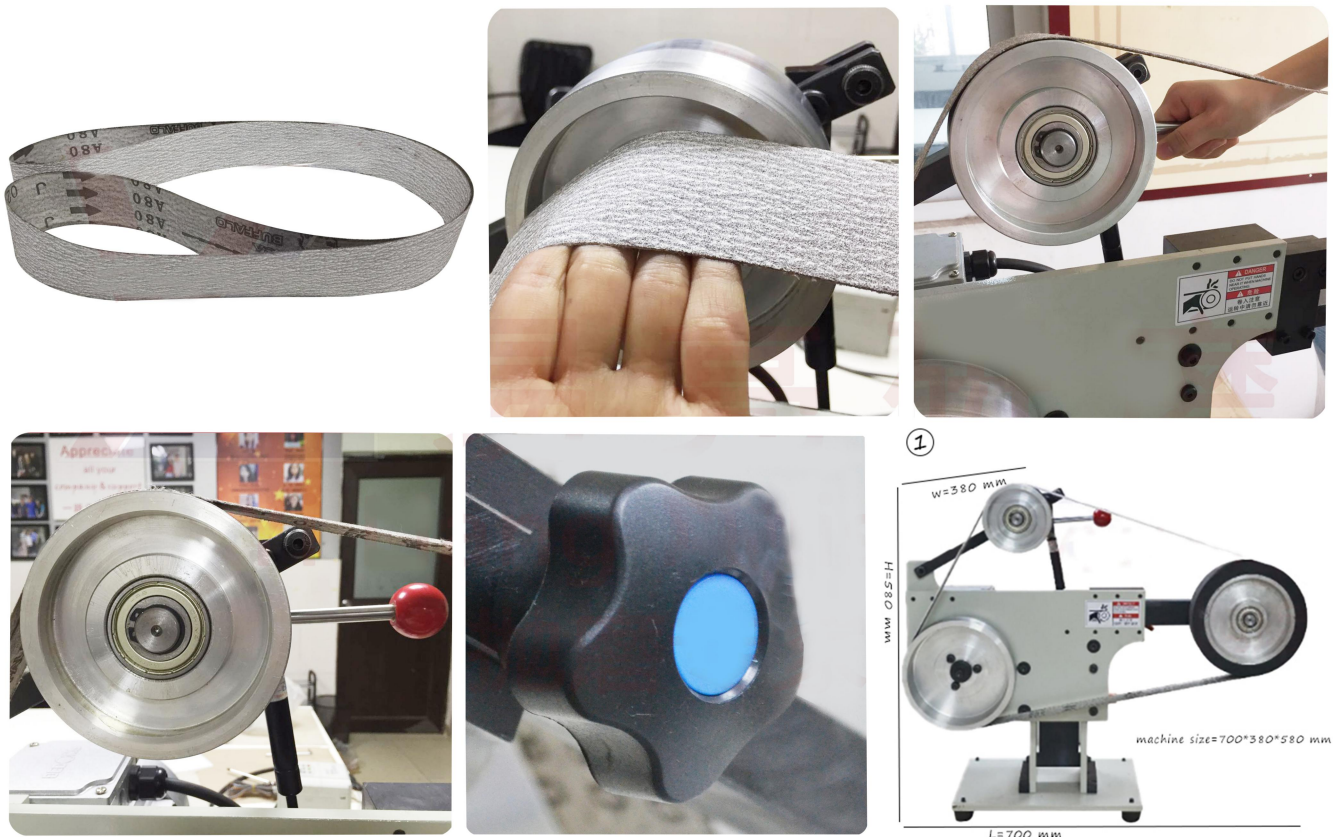

Advanced deburring, grinding and polishing solutions

ADD: Hema Road, Longtang Industrial Park, HeFei China, 230000

TEL/whatsapp: +86 156556556997/+86 17775302563

FAX: +86 551 67365271

EMAIL: melody@advanpolish.com/sales3@advanpolish.com

WEB: www.advgrinding.com/www.advgrinding.en.alibaba.com

10、整机平台可 90 度翻转 working table transform.

扭动松紧开关，即可 90 度翻转整机平台，砂带机可以垂直研磨，也可以水平研磨。

Working table can be changed into vertical type or horizontal type in 90 degrees by twisting loose/fasten button.

11、ADV116-1 立卧两用型砂带机配备矢量变频器，可无极变速。

Vector frequency converter is matched with this machine, speed can change any time.



Advanced deburring, grinding and polishing solutions

ADD: Hema Road, Longtang Industrial Park, HeFei China, 230000

TEL/whatsapp: +86 156556556997/+86 17775302563

FAX: +86 551 67365271

EMAIL: melody@advanpolish.com/sales3@advanpolish.com

WEB: www.advgrinding.com/www.advgrinding.en.alibaba.com

三、特点 Specification

1. ADV116-1 砂带机使用方式多样，一机多用，可塑性高，是 DIY 的首选。
This machine has multiple usages, highly creative. First choice for DIY changing.
2. 机架构件使用 45 号钢平面磨床加工，结构稳固，工作噪音低，震动极微，使用寿命长。
Machine frame is processed with No.45 steel. Stable structure, slight noise, extreme slight vibration.
Long life using
3. 稳定性高，即使 2900r/min，砂带机震动也很小，甚至把一个硬币竖着放在机器上也不会震倒。
Machine with high stability. It has slight vibration even when putting a coin on the machine, rotation up to 2900rpm.
4. 此立卧两用砂带机可以通过变频器无极变速，灵活性高，适用范围广。
Machine can change speed by tuning converter, more flexible and wide use.
5. 用途广泛，适合各种小产品抛磨。例如：刀具、餐具、手机壳、手表、小装饰品等。
Perfect for grinding different kinds of small items, such as knife, spoons, forks, mobile phone shell, watch, small decoration, ect.
6. 操作简单，只需根据个人需求进行不同组合。
Easy operating. Can adjust and change accordingly.

四、注意 Cautions:

小弧磨轮因为直径和轴承外径过小，所以运行速度不能过高，以防止因转速过高引发高温致使轴承损坏。

Since small arc grinding wheel with very small diameter and bearing diameter, speed can not be too fast in case of damaging bearing with high speed.

请使用较慢的速度以延长使用寿命，工作时请留意弧磨轮两端轴承温度变化，以确定最佳转速，建议值 25-30Hz。

Do use slow speed for long-life using. Pay attention to the changes of bearing temperature. Insure the best speed, suggest rotation rate 25-30Hz.



Advanced deburring, grinding and polishing solutions

ADD: Hema Road, Longtang Industrial Park, HeFei China, 230000

TEL/whatsapp: +86 156556556997/+86 17775302563

FAX: +86 551 67365271

EMAIL: melody@advanpolish.com/sales3@advanpolish.com

WEB: www.advgrinding.com/www.advgrinding.en.alibaba.com